

03–320 Mounting of crankshaft

Data



Crankshaft standard dimension and repair stages	Crankshaft bearing journal dia.	Width of journal at fitted bearing	Crankpin dia.	Width of pin
Standard dimension	69.96	34.00	51.96	32.00
	69.95	34.03	51.95	32.10
1st repair stage	69.71	up to 34.60	51.71	up to 32.30
	69.70		51.70	
2nd repair stage	69.46		51.46	
	69.45		51.45	
3rd repair stage	69.21		51.21	
	69.20		51.20	
4th repair stage	68.96		50.96	
	68.95		50.95	

Basic bore and bearing play	Crankshaft bearing	Connecting rod bearing	
Basic bore dia.	74.50	55.60	
	74.52	55.62	
Permissible out-of-round and conicity of basic bore	0.01		
Bearing play radial	when new	0.031–0.068 ¹⁾	0.031–0.068 ¹⁾
	wear limit	0.08	
Bearing play axial	when new	0.10–0.22	0.12–0.26
	wear limit	0.30	0.50

1) For radial play try for mean value.

Bearing shells	Wall thickness crankshaft bearing	Width of fitted bearing shells bearing	Wall thickness connecting rod
Standard dimension	2.25	33.80–33.90	1.80
1st repair stage	2.37	34.40–34.60 ²⁾	1.92
2nd repair stage	2.50		2.05
3rd repair stage	2.62		2.17
4th repair stage	2.75		2.30

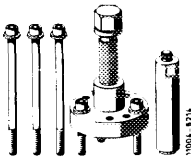
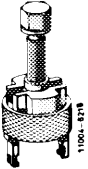
2) The fitted bearing shells for 1st to 4th repair stage are supplied at oversize width and must be finished to fit ground crankshaft bearing journal.

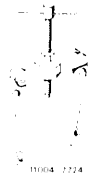
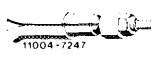
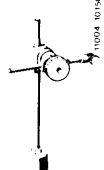
Tightening torques		Nm
Crankshaft bearing bolts		90
Connecting rod nuts	Initial torque	40–50
	Angle of rotation torque	90–100°
Balancing disc to crankshaft		270–330
Neck down screws for flywheel or driven plate	Initial torque	30–40
	Angle of rotation torque	90–100°
Special tools		
Puller for balancing disc		116 589 10 33 00
Puller for crankshaft gear		615 589 01 33 00
Detent		110 589 00 40 00
Countersupport for internal puller		000 589 33 33 00
Internal puller 14.5–18.5 mm for radial ball bearing		000 589 25 33 00
Dial gauge holder for measuring end play		363 589 02 21 00

Note

Engine removed and disassembled.

Main oil ducts in crankcase open. (With steel balls, refer to 01–130). Carefully clean oil ducts in crankcase and crankshaft.

Check crankshaft for cracks, accurate size and hardness (03–318).

Association of crankshaft bearings, installation of crankshaft

1 Install crankshaft bearing caps. Pay attention to identification, 1 is at front.

Do not interchange crankshaft bearing caps.

2 Tighten bolts to 90 Nm.

3 Measure basic bore in direction of A, B and C on 2 levels (conicity).

If a basic bore exceeds the specified value or is conical touch up bearing cap contact on a surface plate up to max. 0.02 mm.

4 Insert crankshaft bearing shells and mount bearing cap. Tighten bolts to 90 Nm.

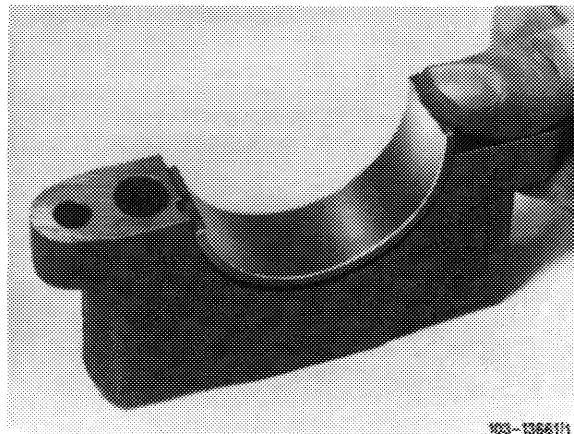
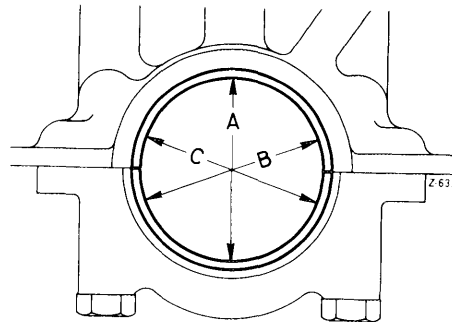
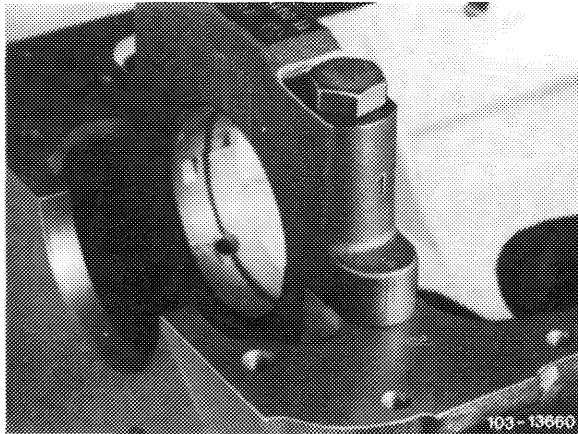

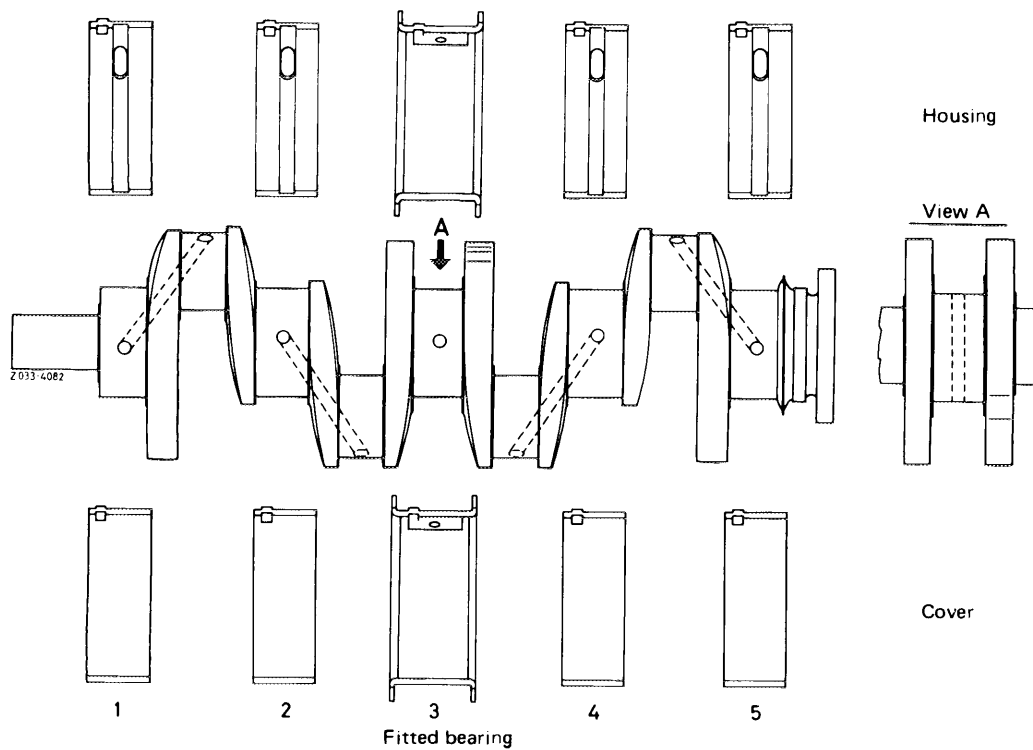

5 Measure and make note of bearing dia.

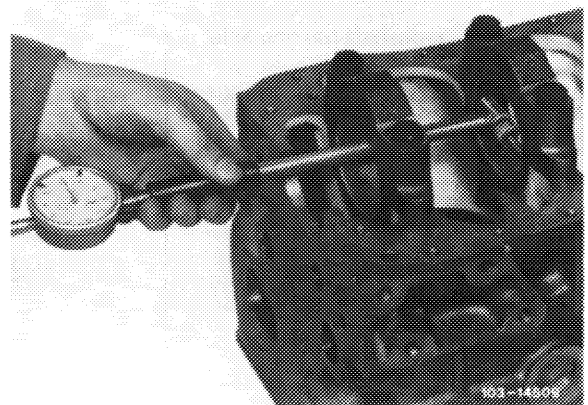

6 Measure crankshaft bearing journal, find crankshaft bearing radial play.

Note: The bearing play can be corrected by changing bearing shells, while trying for mean value of specified bearing play. Crankshaft bearing shells without color coding are thicker than those with blue color coding, while taking into account that the thickness of walls without and with color coding may overlap.

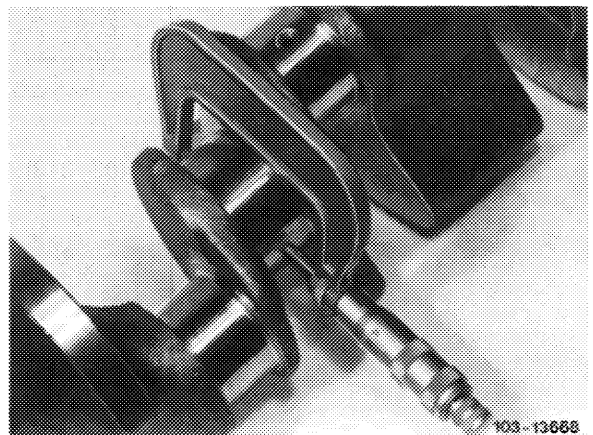

7 Measure width of fitted bearing journal and of fitted bearing.

Find crankshaft bearing axial play.

Note: Fitted shells of repair stages are supplied at oversize.

Machine both fitted bearing shells together on both sides to width of fitted bearing journal, minus axial play. Try for bottom value of 0.10 mm

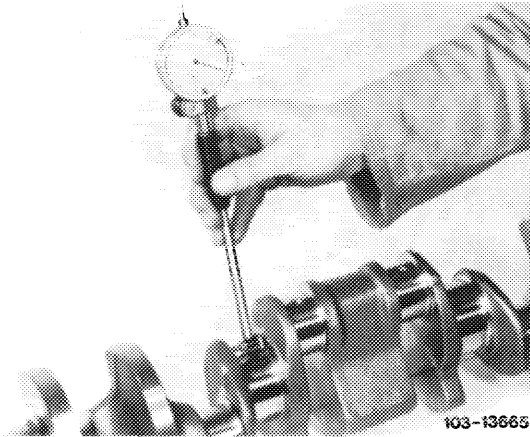

8 Replace rear crankshaft radial sealing ring (03-327).

9 Provide bearing shells, crankshaft and radial sealing ring with engine oil and mount crankshaft.

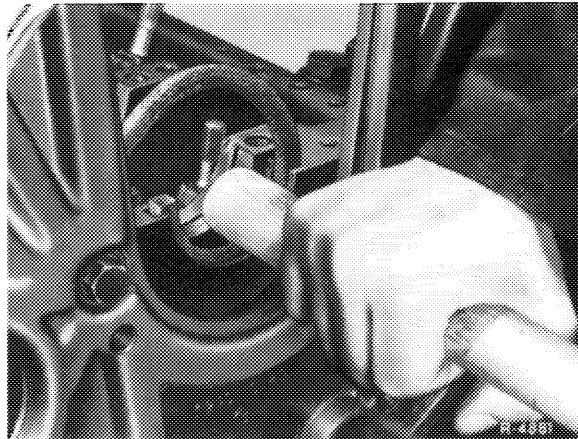

10 Tighten crankshaft bearing caps to 90 Nm.

11 Measure crankshaft bearing axial play.

12 Rotate crankshaft manually and check for easy operation.

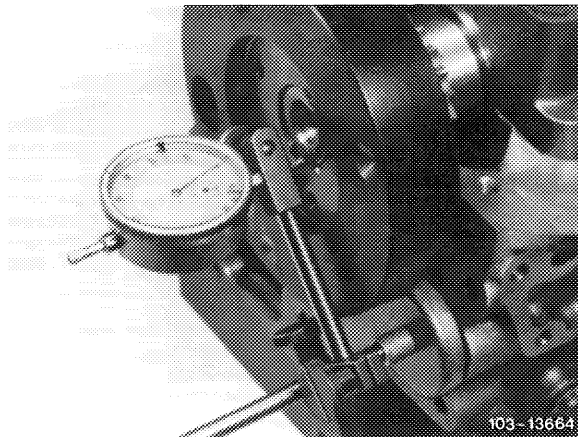

Association of connecting rod bearing and installation of connecting rod

13 Check connecting rod bolts (03-310).

14 Recondition connecting rod and square (03-313).

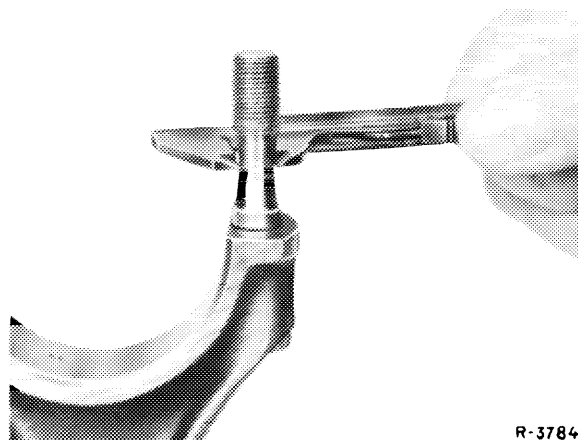

15 Mount connecting rod bearing cap, pay attention to identification. Tighten connecting rod nuts to 40–50 Nm.

16 Measure basic bore in two directions. If a basic bore exceeds the specified value or is conical, touch up bearing cap contact surface on a surface plate up to max. 0.02 mm.

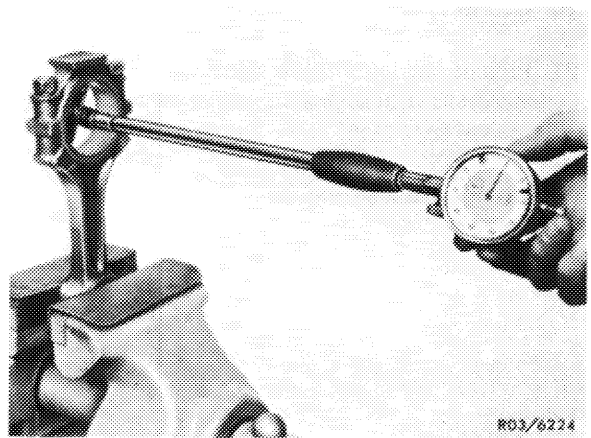

17 Insert connecting rod bearing shells, mount connecting rod bearing cap and bearing shells and tighten connecting rods to 40–50 Nm.

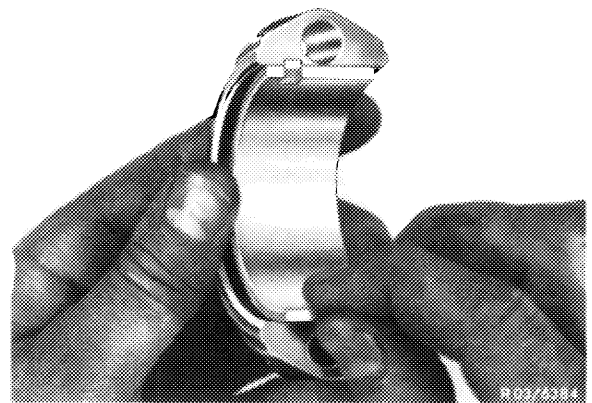

18 Measure and make note of bearing dia.

19 Measure crankpins, determine connecting rod bearing radial play.

Note: The bearing play can be corrected by changing bearing shells, while trying for mean value of specified bearing play. Crankshaft bearing shells without color coding are thicker than those with blue color coding, while taking into account that the thickness of walls without and with color coding may overlap.

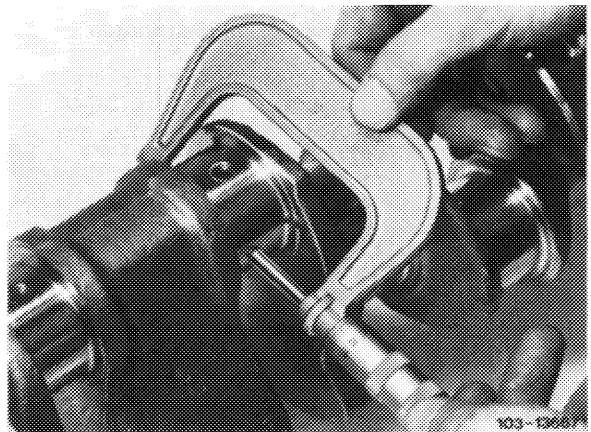

20 Connect piston to connecting rod (03–316).

21 Provide bearing shells, crankshaft, piston and cylinder walls with engine oil, install connecting rod with piston (03–316).

Pay attention to identification.

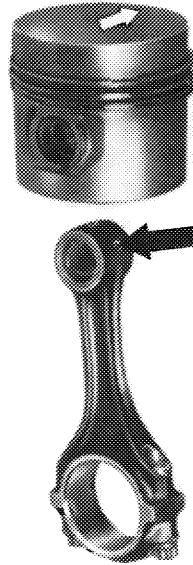

103-9446

22 Tighten connecting rod nuts to 40–50 Nm initial torque and 90–100° angle of rotation torque.

23 Measure connecting rod bearing axial play. Check connecting rod in piston for clearance.

Attention!

Disassemble oil pump and clean, replace if required. Renew oil pressure relief valve. Disassemble oil filter upper half and clean. Carefully clean air-oil cooler.

Install initial operation oil filter element. Change engine oil and oil filter element after 1000–1500 km.

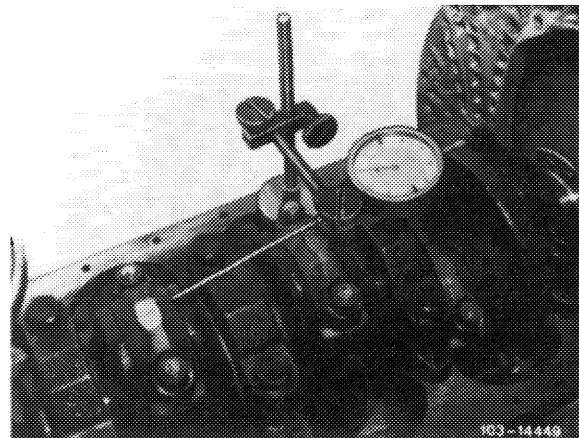

103-1446

Crankshaft and bearing shells

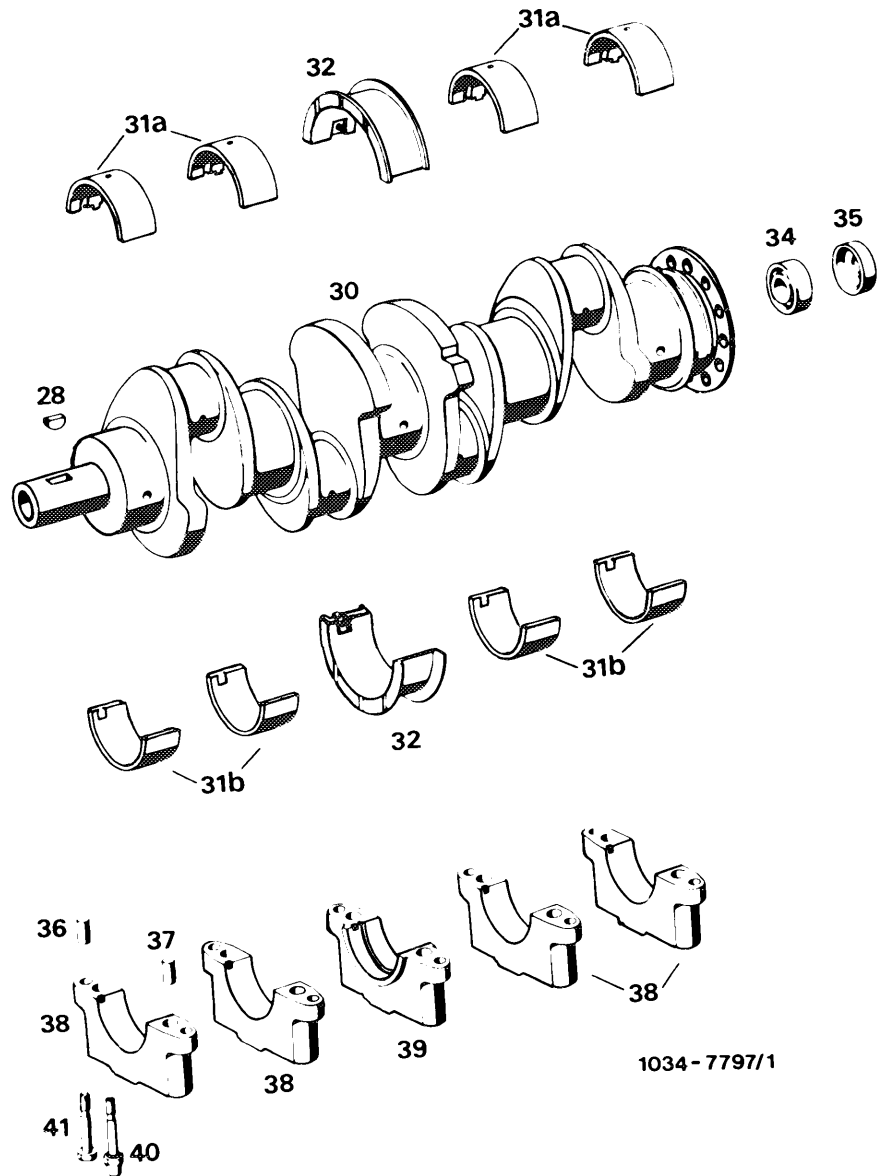

- | | | | |
|-----|-----------------------|----|---|
| 28 | Woodruff key | 36 | 5 cyl. pins 10 m 6 x 16 |
| 30 | Crankshaft | 37 | 5 cyl. pins 8 m 6 x 16 |
| 31a | Upper bearing shells | 38 | Crankshaft bearing cap |
| 31b | Lower bearing shells | 39 | Crankshaft bearing cap – fitted bearing |
| 32 | Fitted bearing shells | 40 | 9 bolts M 12 x 75 |
| 34 | Ball bearing 6202 | 41 | Bolt M 12 x 75 with internal thread |
| 35 | Closing ring | | |