

Model 107 through 07. 1985  
 123  
 126 through 08. 1985

**Brake pad specifications**

Model		107 123 126.02/03 126.1	126.04
Front caliper type		Fixed caliper	Floating caliper
Thickness of brake pad (pad and backing plate)	front rear	17.5 15.5	18.5 15.5
Thickness of pad backing plate	front rear	4.5 5.0	5.5 5.0
Permissible wear <sup>1)</sup> of brake pad down to thickness of	front rear	2.0 2.0	3.5 2.0

1) Replace brake pad during maintenance service if the distance between eye of pad backing plate and cross spring/pad retaining spring on fixed caliper equals approx. 3 mm.

**Brake disk specifications**

Model		107 126	123
Thickness of brake disk	front rear	22 10	12.6 10
Wear limit	front rear	19.4 8.3	10.6 8.3
Limit at maintenance service	front rear	20 8.6	11.1 8.6

**Lubricant**

MB brake pad paste	000 989 10 51
--------------------	---------------

### Special tools

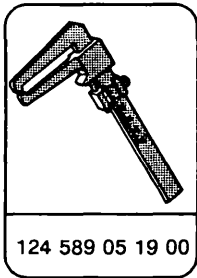
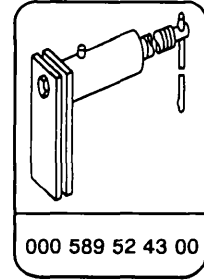
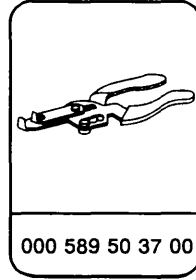
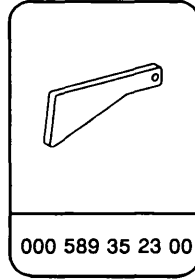
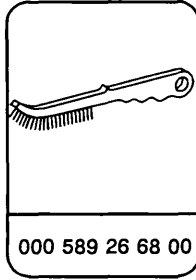
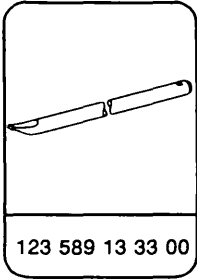

### Brake pad replacement

#### A. Fixed caliper

- On fixed caliper with brake pad wear indicator, pull sensor wire (S10/1) out of plug connection (52) on fixed caliper.

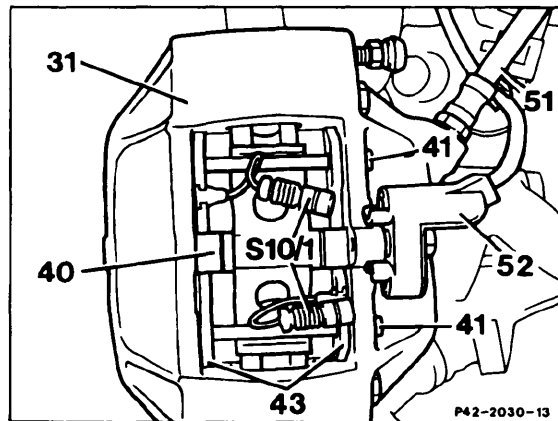

- On Teves (ATE) fixed caliper, knock retaining pins (41) out of fixed caliper by means of punch (035) and remove cross spring/pad retaining spring.

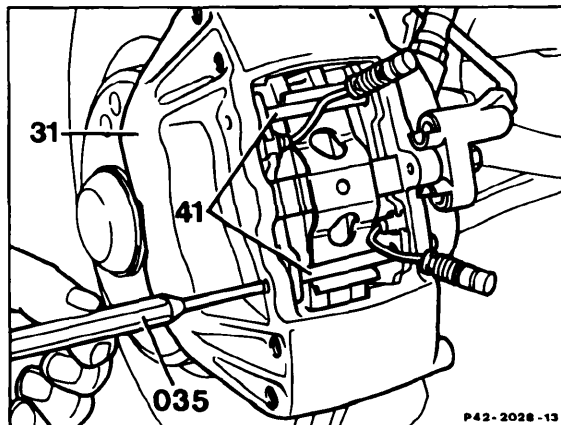

- On Bendix (BX) fixed caliper, remove securing clips (42), retaining pins (41) and springs (40).

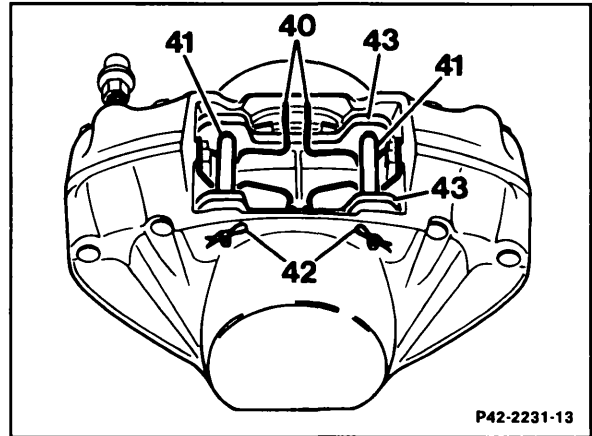

- On Girling caliper, remove securing clips (42) on rear axle, remove retaining pins (41) and plate (40).

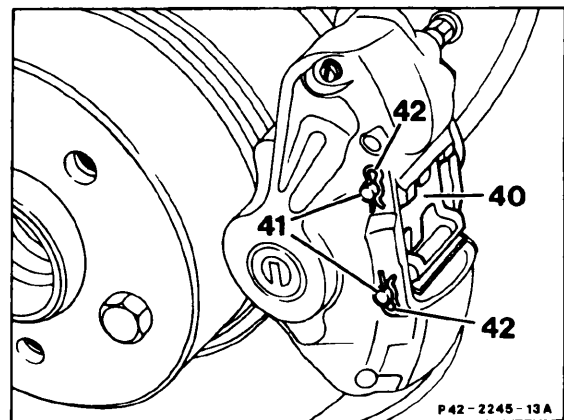

- Remove brake pads (43) from fixed caliper using removing tool (034).

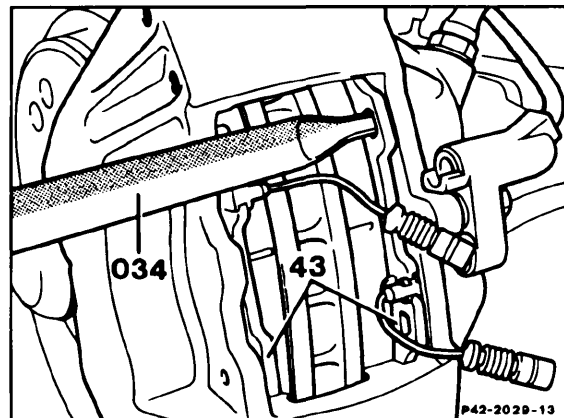

- Pull clip sensors (S10/1) out of pad or backing plate.

On vehicles with ASR, remove sensors from rear pads in addition.

**⚠ CAUTION!**

Replace clip sensors in which the insulating layer of the contact pin has been worn through or where part of the sensor including the wiring insulation is damaged.

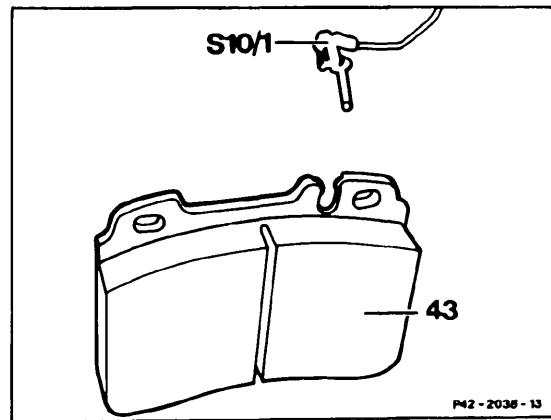

- Clean brake pad guide in fixed caliper using of brake caliper brush (030)
- Visual inspection of dust boots for cracks and piston leaks. If a dust boot is damaged, remove fixed caliper and recondition.

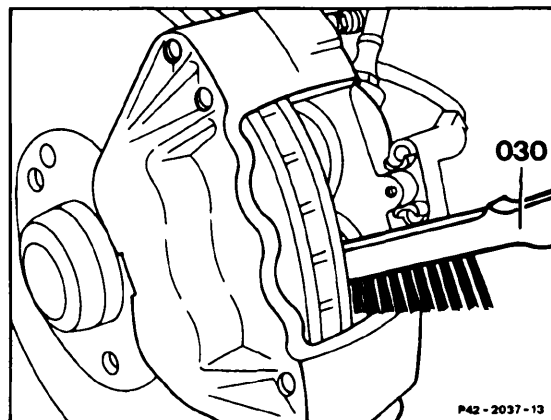

- Push piston back using resetting tool (031), while checking that piston moves freely.

**⚠ CAUTION!**

Use **only** piston resetting tool 000 589 52 43 00. Using other tools may result in damage to the pistons or the dust boots.

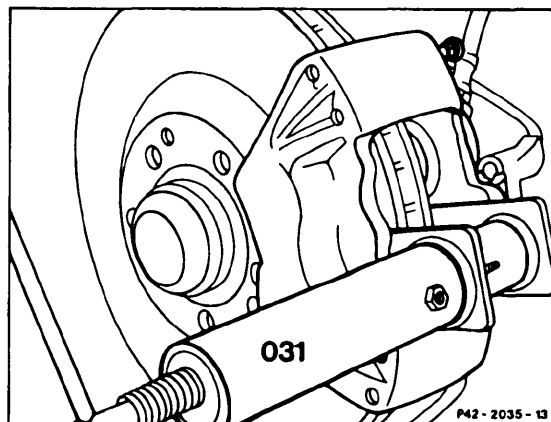

- On rear axle fixed calipers, check the position of the piston (47) in the caliper using the special tool (019).

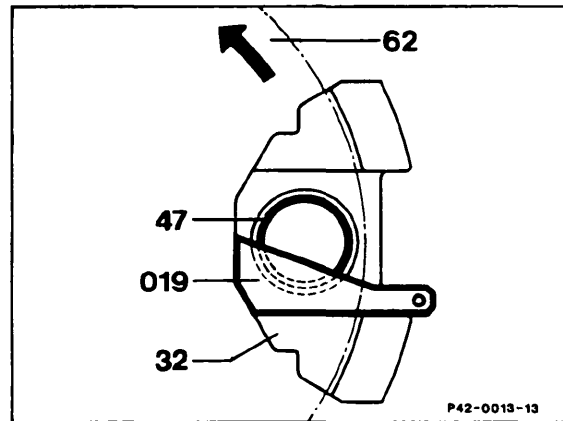

**Note:**

The raised portion of the piston must be positioned at the top on calipers located behind the axle center line (b) on semi-trailing arms suspensions.

However, the raised portion of the piston must be positioned at the bottom on calipers located in front of the axle center line (a) on semi-trailing arms suspensions with torque compensation.

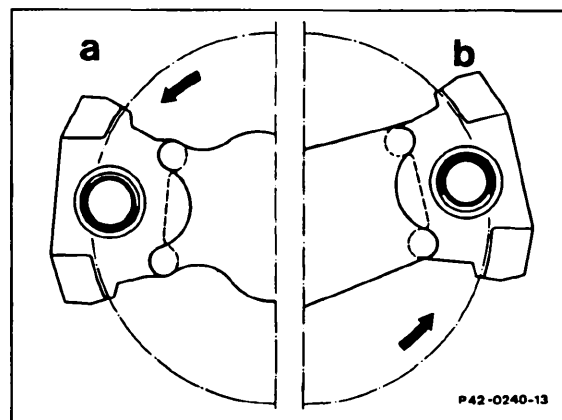

- If necessary, turn piston (47) using special tool (020).
- Clean rain groove in brake pad, measure lining thickness.

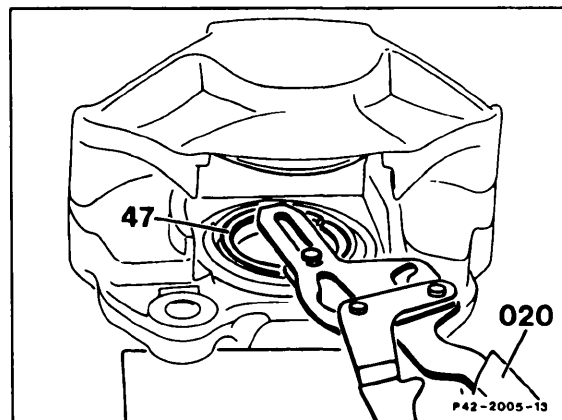

**B. Floating caliper (Model 126.04 up through 08/85 only)**

- Lift the two holding lugs located laterally on cover of plug connector using a screwdriver and open cover. Do not use force.
- Remove cable of clip sensor (56) from plug connection (57) on floating caliper. Do not pull on cable.

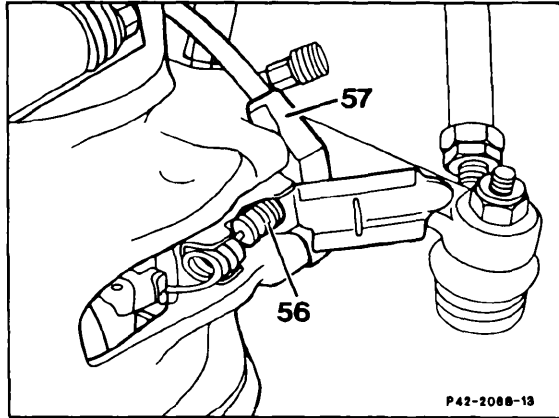

- Unscrew upper hex. bolt while applying counterhold at slide bolt (37).

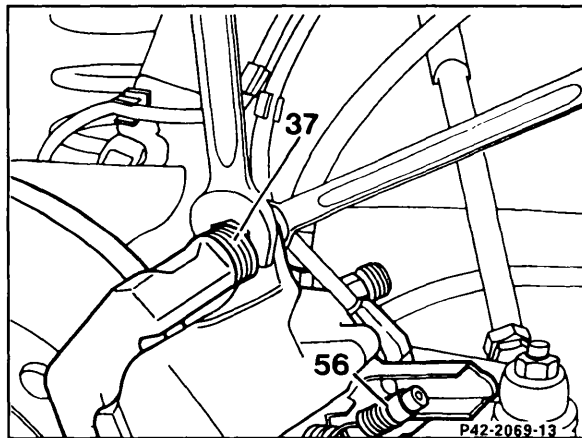

- Swing caliper (34) down and attach to stabilizer bar with suitable hook. Remove both brake pads (43) from brake carrier (33).

**⚠ CAUTION!**

When the caliper housing is swung open, make sure that the guide bolts do not get bent. **Never** use the caliper housing to change the steering angle.

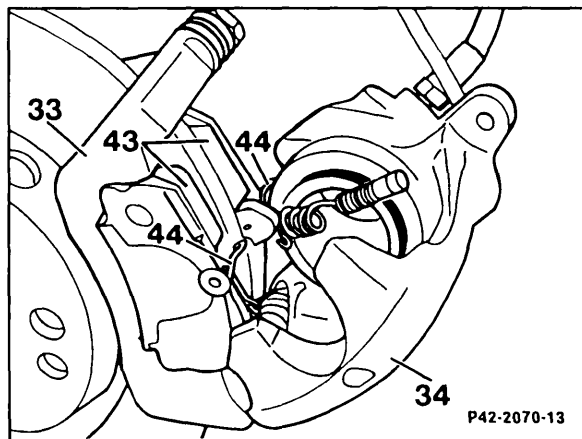

- Pull clip sensor (S10/1) out of pad backing plate.

**Note:** On floating calipers only the inner brake pad has a wear indicator.

**⚠ CAUTION!**

Replace clip sensors on which the insulation layer of the contact plate is worn through or where part of the sensor including the wiring insulation is damaged.

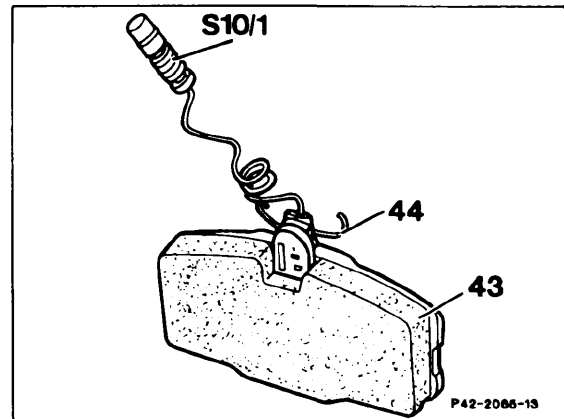

- Clean brake pad supporting surface of brake carrier.
- Check dust boot (45) for cracks and piston for leakage. If dust boot is damaged, remove and repair caliper, since the entrance of dirt will quickly lead to caliper leakage.

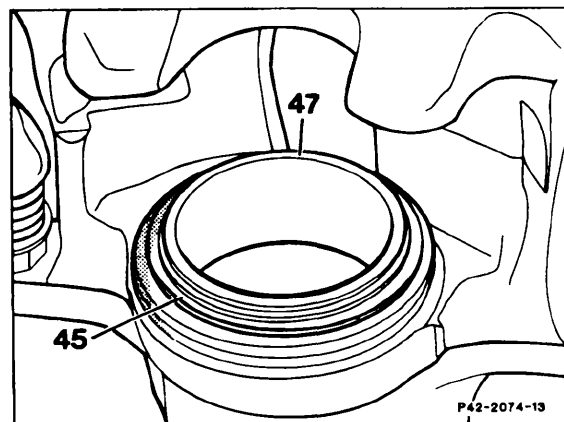

- Push piston back using resetting tool (031).

**⚠ CAUTION!**

Use **only** piston resetting tool 000 589 52 43 00. Using other tools may result in damage to the pistons or the dust boots.

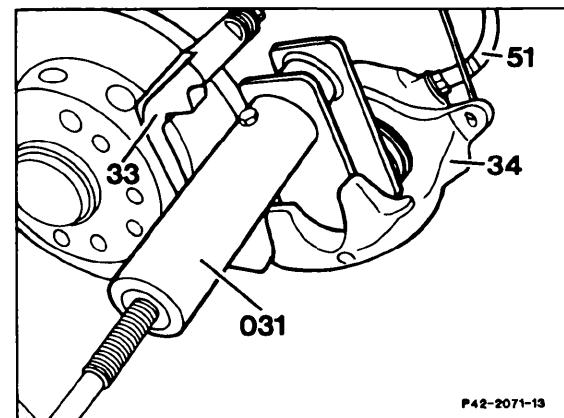

### Checking brake disks

- Check brake disks for score marks and cracks. Cracks in a circumferential direction up to 0.5 mm in depth are permitted.

**Note:**

Brake disks which are badly discolored - grey or blue discoloration should be cleaned with cleaning pads (at extra cost).

Measure thickness of brake disk using special tool (035).

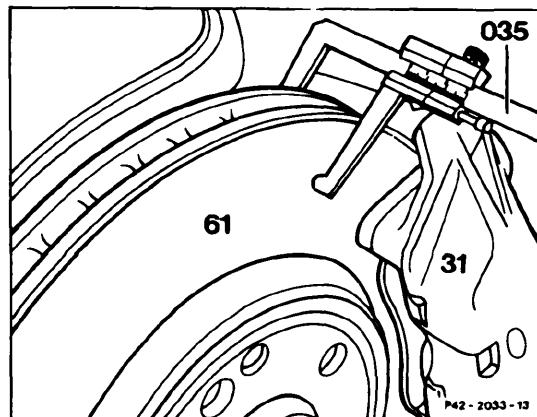

**Note:**

Wear limits for brake disks must be strictly observed.

To ensure that brake disk does not exceed wear limit before next maintenance service, observe wear limits in chart at beginning of chapter.

Ventilated brake disks with hairline cracks up to 25 mm in length, which may show up under high loads, need not be replaced. Replace disks with open cracks and score marks deeper than 0.5 mm immediately.



- Clean air passages of vented brake disks with a thin wire, taking care not to dislodge any balancing weights. Blow loosened dirt out of passages with compressed air.

**Note:**

Badly clogged air passages can be cleaned only by removing brake disks and placing them in a washing unit.

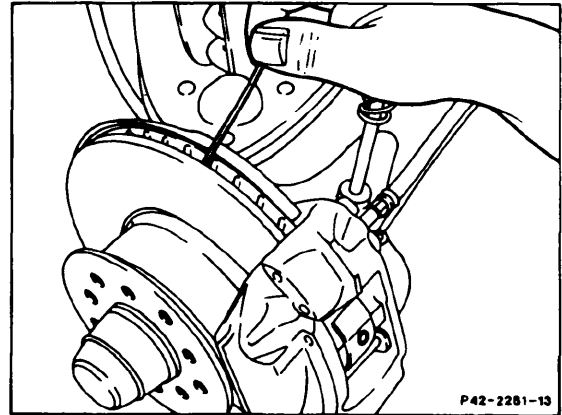

## Brake pad Installation

### A. Fixed caliper

- On fixed caliper, apply heat resistant long term lubricant to brake pads at spots indicated by arrows. Then install brake pads.
- Install cross spring/pad retaining springs, holding plate for pads, retaining pins, and locking clips, as required.
- On fixed caliper with brake pad wear indicator, insert clip sensors (S10/1) into brake pad (43) and into plug connector (52).

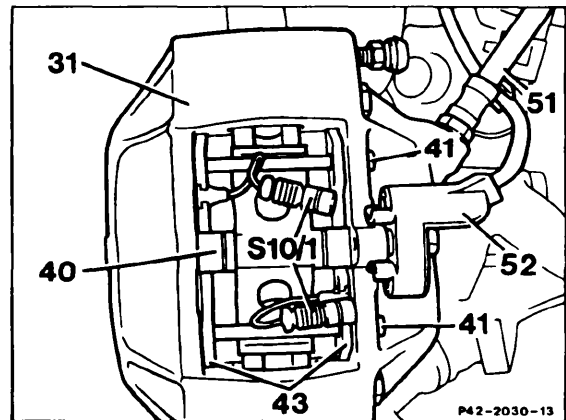
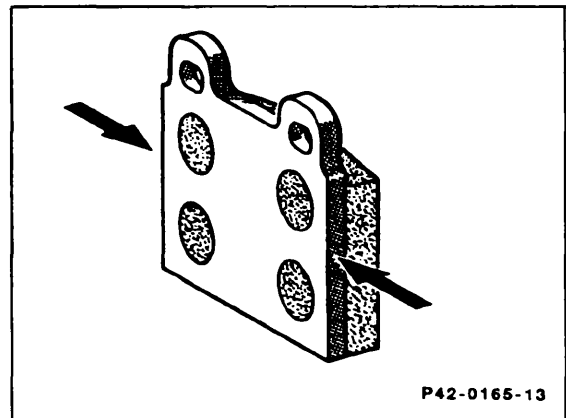

**Note:**

The rear brakes on vehicles equipped with ASR II have wear sensors as on the front brakes.

The same wear sensors (S10/3) are used on the rear wheels as are used on the front wheels.

The wires must be routed as shown in the illustration

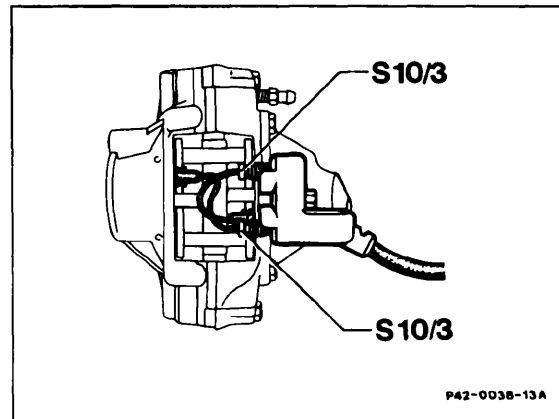

- **Apply brakes vigorously several times** until strong resistance is felt. Then check brake fluid level in reservoir and add, as necessary.

If new brake pads are installed, they must be broken-in carefully by stopping several times from 80 to 40 km/h with light pedal pressure.

Allow brakes to cool between each application. Hard braking should only be done with pads that have been broken-in.

### B. Floating caliper (Model 126.04 up through 08/85 only)

- On floating caliper, insert both brake pads (43) into brake carrier (33), making sure that the spring clip (44) is located parallel with upper edge of pad.
- Plug clip sensor into inner brake pad.

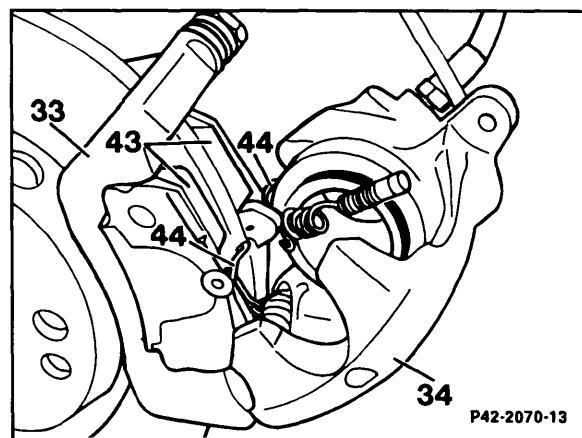

- Secure caliper (34) with new self locking bolt to brake carrier (33) while applying counterhold to slide bolts (37). Torque to 35 Nm.

**Note: Do not re-use self locking bolts.**

- Coil cable of clip sensor (56) and insert into plug connector (57) on floating caliper. Close cover of plug connector.

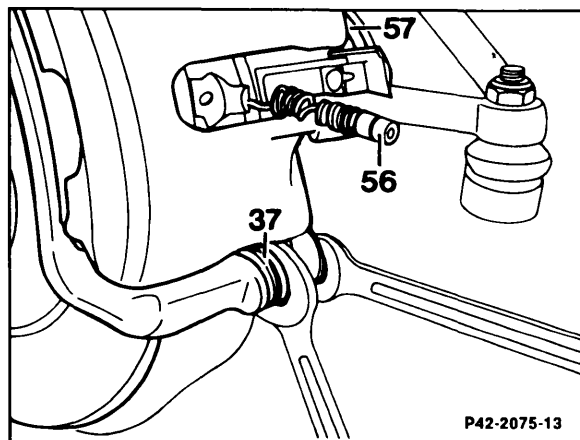

- Apply brakes vigorously several times until strong resistance is felt. Then check brake fluid level in reservoir and add, as necessary.

If new brake pads are installed, they must be broken-in carefully by stopping several times from 80 to 40 km/h with light pedal pressure.

Allow brakes to cool between each application. Hard braking should only be done with pads that have been broken-in.